



## APPLICATION NOTE

# Proper Temperature Measurement and PCB Mounting for DC-DC Power Converters

## DC-DC CONVERTERS AND ACCESSORIES



**Contents:**

Introduction ..... 3

Proper Temperature Measurement Location ..... 4

Proper PCB Mounting for Heat Removal ..... 5

Figure 3. – Thermal copper plane used to carry heat from the converter to a chassis or heatsink.  
..... 6

Contact Information ..... 6



## Introduction

The temperature rise and heat dissipation of the DC-DC converter must be considered during the system mechanical and thermal design to ensure the converter does not exceed its maximum rated operating temperature. This short form application note describes simply the proper temperature measurement locations, and proper PCB mounting of converters to ensure that heat is measured and removed correctly to keep the converter at or below the maximum rated operating temperature. For a more detailed and in-depth engineering explanation of the thermal considerations and mounting options for converters, including heat sinking, please request VPT's application note titled "Thermal Considerations for Hybrid DC-DC Power Converters".

Critical applications range from undersea to military ground to commercial and military avionics to deep space. DC-DC converters, point of load converters, EMI filters and other power modules are offered by various manufacturers, all claiming high reliability. The question is, how do you know what level of quality and reliability you are getting, and how do you select the correct level for your application?

## Proper Temperature Measurement Location

The operating temperature is specified, and must be measured on the bottom surface (baseplate) of the case. The lid offers very little path for heat transfer. Any temperatures measured on the lid will give inaccurate results, and any heatsinking added to the lid will have only minimal effect. See Figure 1 below:

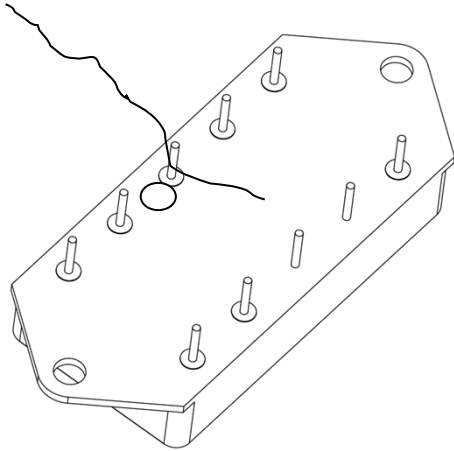

Correct Thermocouple Placement

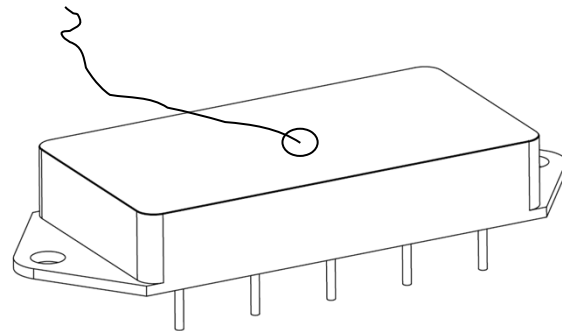

***In-correct*** Thermocouple Placement

Figure 1. – Proper Temperature Measurement Location.

## Proper PCB Mounting for Heat Removal

The thermal path is entirely through the bottom / baseplate of the package. For power converters mounted to a PCB, the proper mounting technique involves ensuring that the converter is securely touching the PCB for optimal heat transfer. A thermally conductive gap filler material should be used between the mounting surface of the hybrid and the PCB. This gap filler is typically a thermal pad, thermal grease, or adhesive. It will fill any surface irregularities and decrease the thermal resistance of the interface. The DC-DC converter should be mounted securely to the PCB for good thermal conductivity. The flange package, adhesive, or a mounting strap is recommended for best performance. Some gap filler materials require adequate mounting pressure to maintain good thermal performance. Solder connections to the pins are usually not sufficient if a good thermal interface is required. See figure 2 below:

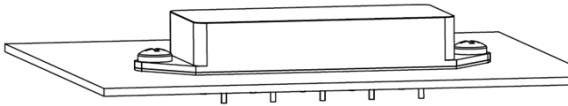

Correct PCB Mounting  
(thermal pad, converter baseplate secure to PCB)

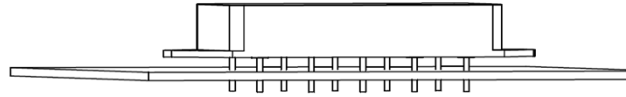

*In-correct* PCB Mounting  
(gap between baseplate and PCB)

Figure 2. – Proper Mounting to a PCB.

When the PCB alone is not sufficient to carry heat away from the hybrid, thermal vias or a thermal plane built into the PCB can be added to the assembly to carry heat to a chassis or heatsink as shown in Figure 3 below:

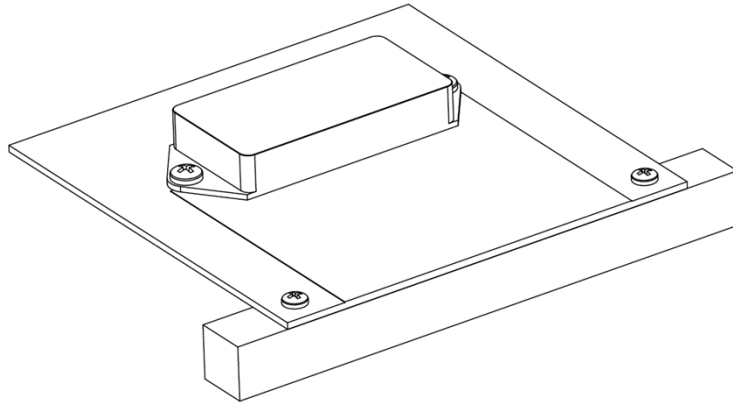

Figure 3. – Thermal copper plane used to carry heat from the converter to a chassis or heatsink.

## Contact Information

For further information about any of VPT's products, policies, or programs contained herein, or to request a quotation or place orders, please contact your sales representative or the VPT Inc. Sales Department at:

**Phone:** (425) 353-3010  
**Fax:** (425) 353-4030  
**E-mail:** [vptsales@power.com](mailto:vptsales@power.com)  
**Website:** [www.vptpower.com](http://www.vptpower.com)

**Sales & Marketing Headquarters:**  
19909 120th Avenue NE  
Suite 102  
Bothell, WA 98011

**Company Headquarters:**  
1971 Kraft Drive  
Blacksburg, VA 24060