

### DESCRIPTION

The VPT5 series of isolated COTS DC-DC converters is a cost effective solution for many demanding high reliability applications. A wide input voltage range accommodates nominal 28V inputs including avionics, mobile, ground systems, and other applications. Low input and output ripple, fixed operating frequency, and companion EMI filters simplify system design and compliance. A proven design heritage, no optoisolators and a rugged all metal package ensure long term reliability.

The VPT5 series is intended for harsh environments including severe vibration, shock and temperature cycling. Testing is to JESD22, MIL-STD-810, and MIL-STD-883.

These converters are designed and manufactured in a facility certified to ISO9001, J-STD-001 and IPC-A-610.

This product may incorporate one or more of the following U.S. patents:

5,784,266  
5,790,389  
5,963,438  
5,999,433  
6,005,780  
6,084,792  
6,118,673

### FEATURES

- High Reliability at Low Cost
- 5 Watts Output Power
- Wide Input Voltage Range: 15 to 50 Volts per MIL-STD-704 and MIL-STD-1275
- High Input Transient Voltage: 80 Volts for 1 sec per MIL-STD-704A
- Input Undervoltage Lockout
- Fixed Frequency
- Output Soft Start
- Current Limit Protection
- Short Circuit Protection
- Magnetic Feedback, no Optoisolators
- Wide Temperature Range, -55°C to 100°C
- Internally Conformal Coated
- Standard Six Sided Non-Hermetic Rugged Metal Package
- Meets MIL-STD-461 Revisions C, D, E and F EMC Requirements When Used With VPT's EMI Filters



Figure 1 – VPT5-2800D DC-DC Converter

(Not to Scale)



# VPT5-2800D Series

## SPECIFICATIONS (T<sub>CASE</sub> = -55°C to +100°C, V<sub>IN</sub> = +28V ± 5%, Full Load, Unless Otherwise Specified)

### ABSOLUTE MAXIMUM RATINGS

Input Voltage (Continuous)	50 V <sub>DC</sub>	Junction Temperature Rise to Case	+15°C
Input Voltage (Transient, 1 second)	80 Volts	Storage Temperature	-55°C to +125°C
Output Power	5 Watts	Lead Solder Temperature (10 seconds)	300°C
Power Dissipation (Full Load, T <sub>CASE</sub> = +100°C)	2.5 Watts	Weight (Maximum)	24 Grams

Parameter	Conditions	VPT5-2805D			VPT5-2812D			Units
		Min	Typ	Max	Min	Typ	Max	
<b>STATIC</b>								
INPUT Voltage <sup>4</sup>	Continuous	15	28	50	15	28	50	V
	Transient, 1 sec	-	-	80	-	-	80	V
Current	Inhibited	-	4	6	-	4	6	mA
	No Load	-	40	60	-	40	60	mA
Ripple Current	Full Load, 20Hz to 10MHz	-	30	50	-	30	50	mA <sub>p-p</sub>
Inhibit Pin Input <sup>4</sup>		0	-	1.5	0	-	1.5	V
Inhibit Pin Open Circuit Voltage <sup>4</sup>		9.0	11.0	13.0	9.0	11.0	13.0	V
UVLO Turn On		12.0	-	14.8	12.0	-	14.8	V
UVLO Turn Off <sup>4</sup>		11.0	-	14.5	11.0	-	14.5	V
OUTPUT Voltage <sup>5</sup>	+V <sub>OUT</sub> T <sub>CASE</sub> = 25°C	4.92	5.00	5.08	11.70	12.00	12.30	V
	+V <sub>OUT</sub> T <sub>CASE</sub> = -55°C to +100°C	4.87	5.00	5.13	11.58	12.00	12.42	V
	-V <sub>OUT</sub> T <sub>CASE</sub> = 25°C	4.87	5.00	5.13	11.70	12.00	12.30	V
	-V <sub>OUT</sub> T <sub>CASE</sub> = -55°C to +100°C	4.82	5.00	5.18	11.58	12.00	12.42	V
Power <sup>3,6</sup>	Total	0	-	5	0	-	5	W
	±V <sub>OUT</sub> Either Output	0	-	3.5	0	-	3.5	W
Current <sup>3,6</sup>	±V <sub>OUT</sub> Either Output	0	-	0.70	0	-	0.29	A
Ripple Voltage	±V <sub>OUT</sub> Full Load <sup>5</sup> , 20Hz to 10MHz	-	35	75	-	20	50	mV <sub>p-p</sub>
Line Regulation	+V <sub>OUT</sub> V <sub>IN</sub> = 15V to 50V	-	1	10	-	1	10	mV
	-V <sub>OUT</sub> V <sub>IN</sub> = 15V to 50V	-	5	50	-	30	150	mV
Load Regulation	+V <sub>OUT</sub> No Load to Full Load <sup>5</sup>	-	1	15	-	1	25	mV
	-V <sub>OUT</sub> No Load to Full Load <sup>5,7</sup>	-	20	100	-	55	200	mV
Cross Regulation	-V <sub>OUT</sub> +Load 70%, -Load 30% +Load 30%, -Load 70%	-	150	300	-	200	300	mV
EFFICIENCY	Full Load <sup>5</sup>	67	73	-	69	74	-	%
LOAD FAULT POWER DISSIPATION	Overload <sup>4</sup>	-	-	5	-	-	5	W
CAPACITIVE LOAD <sup>4</sup>	Either Output	-	-	300	-	-	100	μF
SWITCHING FREQUENCY		425	500	550	425	500	550	kHz
ISOLATION	500 V <sub>DC</sub>	100	-	-	100	-	-	MΩ
MTBF (MIL-HDBK-217F)	GM @ T <sub>C</sub> = 55°C	-	363	-	-	363	-	kHrs

See notes on next page.



# VPT5-2800D Series

## SPECIFICATIONS (T<sub>CASE</sub> = -55°C to +100°C, V<sub>IN</sub> = +28V ± 5%, Full Load, Unless Otherwise Specified)

### ABSOLUTE MAXIMUM RATINGS

Input Voltage (Continuous)	50 V <sub>DC</sub>	Junction Temperature Rise to Case	+15°C
Input Voltage (Transient, 1 second)	80 Volts	Storage Temperature	-55°C to +125°C
Output Power <sup>1</sup>	5 Watts	Lead Solder Temperature (10 seconds)	300°C
Power Dissipation (Full Load, T <sub>CASE</sub> = +100°C)	2.5 Watts	Weight (Maximum)	24 Grams

Parameter	Conditions	VPT5-2805D			VPT5-2812D			Units	
		Min	Typ	Max	Min	Typ	Max		
<b>DYNAMIC</b>									
Load Step Output Transient	±V <sub>OUT</sub>	Half Load to Full Load	-	65	150	-	100	200	mV <sub>PK</sub>
Load Step Recovery <sup>2</sup>			-	150	300	-	200	500	μSec
Line Step Output Transient <sup>4</sup>	±V <sub>OUT</sub>	V <sub>IN</sub> = 16V to 40V	-	20	50	-	55	120	mV <sub>PK</sub>
Turn On Delay	±V <sub>OUT</sub>	V <sub>IN</sub> = 0V to 28V	-	10	20	-	10	20	mSec
Turn On Overshoot			-	0	25	-	0	50	mV <sub>PK</sub>

- Notes:
1. Dependent on output voltage
  2. Time for output voltage to settle within 1% of its nominal value
  3. Derate linearly to 0 at 110°C
  4. Verified by qualification testing
  5. Half load at +V<sub>OUT</sub> and half load at -V<sub>OUT</sub>
  6. Up to 70% of the total power or current can be drawn from either of the two outputs
  7. 5% Load to Full Load at -55°C

## SPECIFICATIONS (T<sub>CASE</sub> = -55°C to +100°C, V<sub>IN</sub> = +28V ± 5%, Full Load, Unless Otherwise Specified)

### ABSOLUTE MAXIMUM RATINGS

Input Voltage (Continuous)	50 V <sub>DC</sub>	Junction Temperature Rise to Case	+15°C
Input Voltage (Transient, 1 second)	80 Volts	Storage Temperature	-55°C to +125°C
Output Power <sup>1</sup>	5 Watts	Lead Solder Temperature (10 seconds)	300°C
Power Dissipation (Full Load, T <sub>CASE</sub> = +100°C)	2.5 Watts	Weight (Maximum)	24 Grams

Parameter	Conditions	VPT5-2815D			Units	
		Min	Typ	Max		
<b>STATIC</b>						
INPUT Voltage <sup>4</sup>	Continuous	15	28	50	V	
	Transient, 1 sec	-	-	80	V	
Current	Inhibited	-	4	6	mA	
	No Load	-	40	60	mA	
Ripple Current	Full Load <sup>5</sup> , 20Hz to 10MHz	-	30	50	mA <sub>p-p</sub>	
Inhibit Pin Input <sup>4</sup>		0	-	1.5	V	
Inhibit Pin Open Circuit Voltage <sup>4</sup>		9.0	11.0	13.0	V	
UVLO Turn On		12.0	-	14.8	V	
UVLO Turn Off <sup>4</sup>		11.0	-	14.5	V	
OUTPUT Voltage	+V <sub>OUT</sub> T <sub>CASE</sub> = 25°C	14.62	15.0	15.38	V	
	+V <sub>OUT</sub> T <sub>CASE</sub> = -55°C to +100°C	14.47	15.0	15.53	V	
	-V <sub>OUT</sub> T <sub>CASE</sub> = 25°C	14.62	15.0	15.38	V	
	-V <sub>OUT</sub> T <sub>CASE</sub> = -55°C to +100°C	14.47	15.0	15.53	V	
Power <sup>3,6</sup>	Total	0	-	5	W	
	±V <sub>out</sub>	Either Output	0	-	3.5	W
Current <sup>3,6</sup>	±V <sub>OUT</sub>	Either Output	0	-	0.23	A
Ripple Voltage	±V <sub>OUT</sub> Full Load <sup>5</sup> , 20Hz to 10MHz	-	20	50	mV <sub>p-p</sub>	
Line Regulation	+V <sub>OUT</sub> V <sub>IN</sub> = 15V to 50V	-	1	10	mV	
	-V <sub>OUT</sub> V <sub>IN</sub> = 15V to 50V	-	30	150	mV	
Load Regulation	+V <sub>OUT</sub> No Load to Full Load <sup>5</sup>	-	1	25	mV	
	-V <sub>OUT</sub> No Load to Full Load <sup>5,7</sup>	-	55	200	mV	
Cross Regulation	-V <sub>OUT</sub> +Load 70%, -Load 30% +Load 30%, -Load 70%	-	200	300	mV	
EFFICIENCY	Full Load <sup>5</sup>	70	75	-	%	
LOAD FAULT POWER DISSIPATION	Overload <sup>4</sup>	-	-	5	W	
CAPACITIVE LOAD <sup>4</sup>	Either Output	-	-	100	μF	
SWITCHING FREQUENCY		425	500	550	kHz	
ISOLATION	500 V <sub>DC</sub>	100	-	-	MΩ	
MTBF (MIL-HDBK-217F)	GM @ T <sub>C</sub> = 55°C	-	363	-	kHrs	

See notes on next page.

## SPECIFICATIONS (T<sub>CASE</sub> = -55°C to +100°C, V<sub>IN</sub> = +28V ± 5%, Full Load, Unless Otherwise Specified)

### ABSOLUTE MAXIMUM RATINGS

Input Voltage (Continuous)	50 V <sub>DC</sub>	Junction Temperature Rise to Case	+15°C
Input Voltage (Transient, 1 second)	80 Volts	Storage Temperature	-55°C to +125°C
Output Power <sup>1</sup>	5 Watts	Lead Solder Temperature (10 seconds)	300°C
Power Dissipation (Full Load, T <sub>CASE</sub> = +100°C)	2.5 Watts	Weight (Maximum)	24 Grams

Parameter	Conditions	VPT5-2815D			Units
		Min	Typ	Max	
<b>DYNAMIC</b>					
Load Step Output Transient ±V <sub>OUT</sub>	Half Load to Full Load <sup>5</sup>	-	100	200	mV <sub>PK</sub>
Load Step Recovery <sup>2</sup>		-	200	500	μSec
Line Step Output Transient <sup>4</sup> ±V <sub>OUT</sub>	V <sub>IN</sub> = 16V to 40V	-	55	150	mV <sub>PK</sub>
Turn On Delay ±V <sub>OUT</sub>	V <sub>IN</sub> = 0V to 28V	-	10	20	mSec
Turn On Overshoot		-	0	50	mV <sub>PK</sub>

- Notes:
1. Dependent on output voltage
  2. Time for output voltage to settle within 1% of its nominal value
  3. Derate linearly to 0 at 110°C
  4. Verified by qualification testing
  5. Half load at +V<sub>OUT</sub> and half load at -V<sub>OUT</sub>
  6. Up to 70% of the total power or current can be drawn from any one of the two outputs
  7. 5% Load to Full Load at -55°C

## BLOCK DIAGRAM

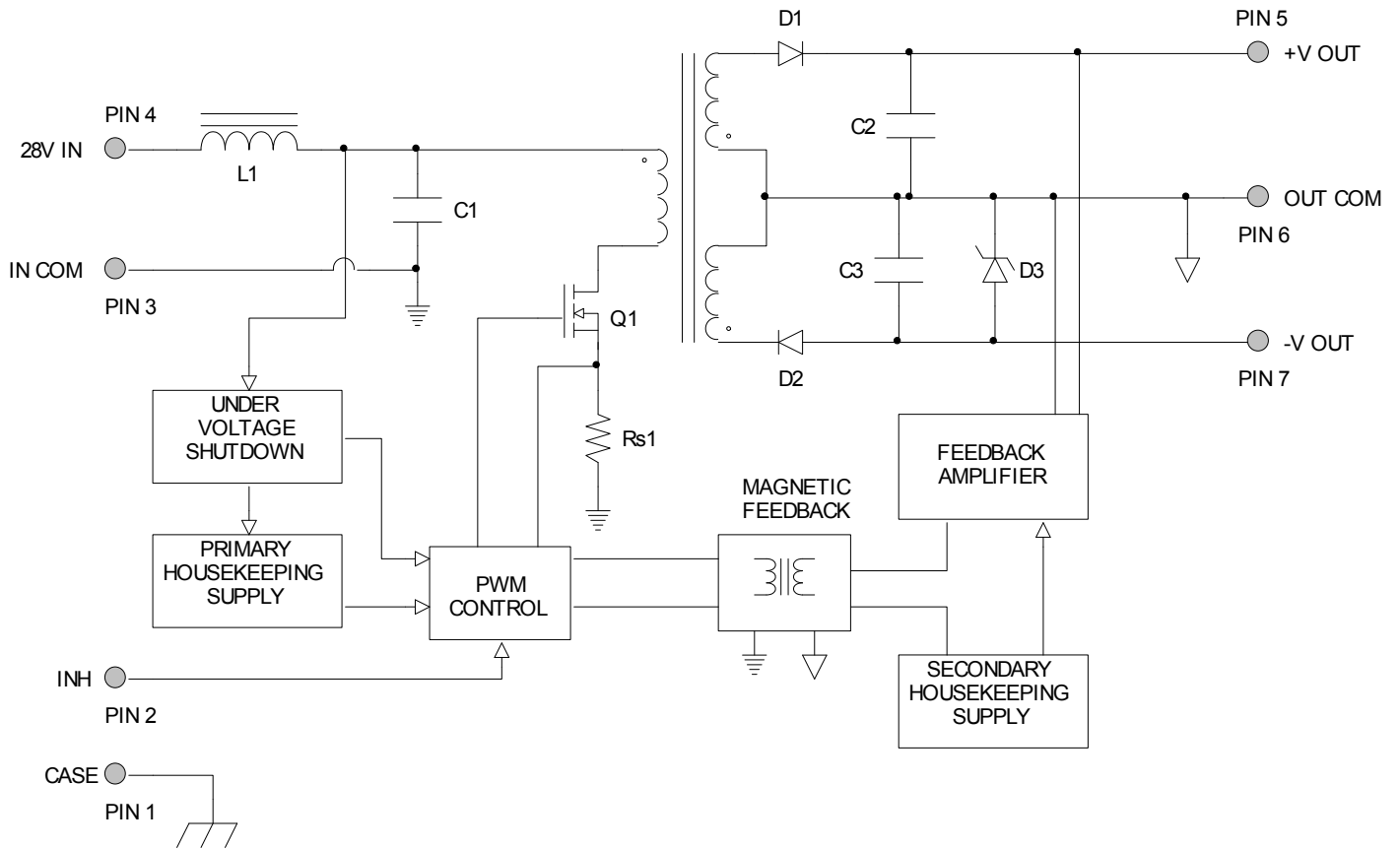

Figure 2

## CONNECTION DIAGRAM

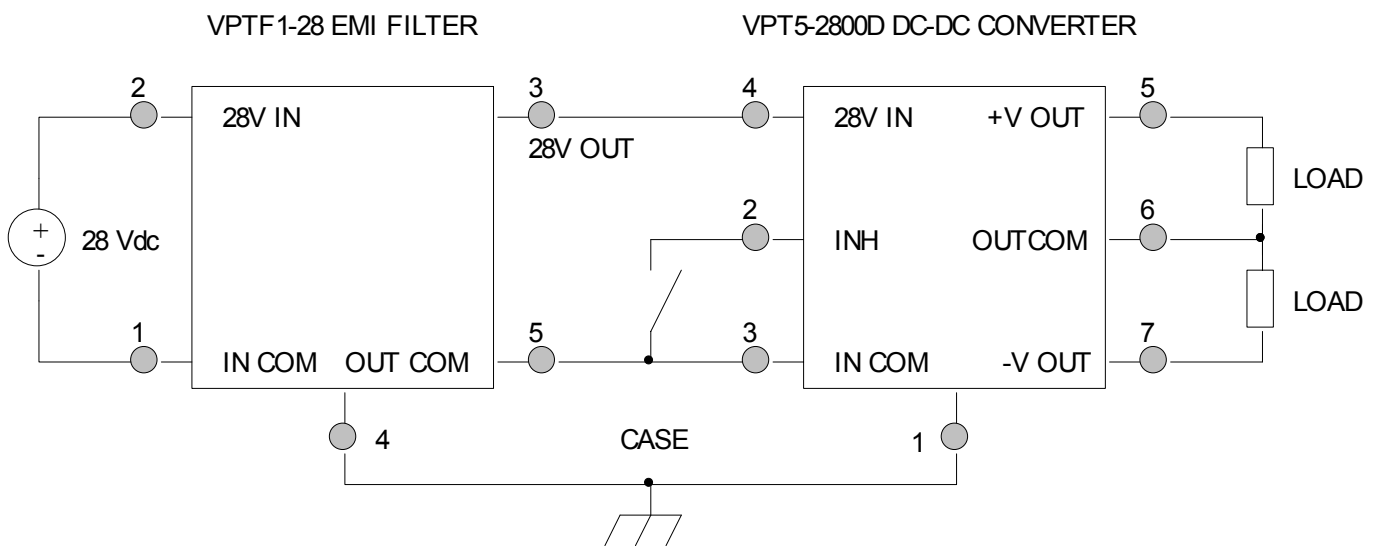
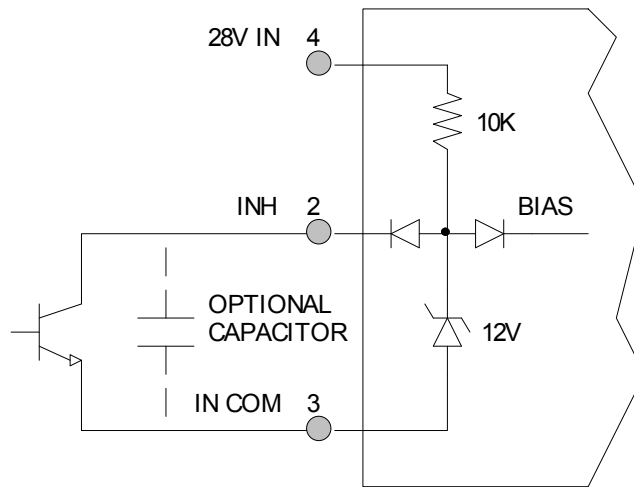
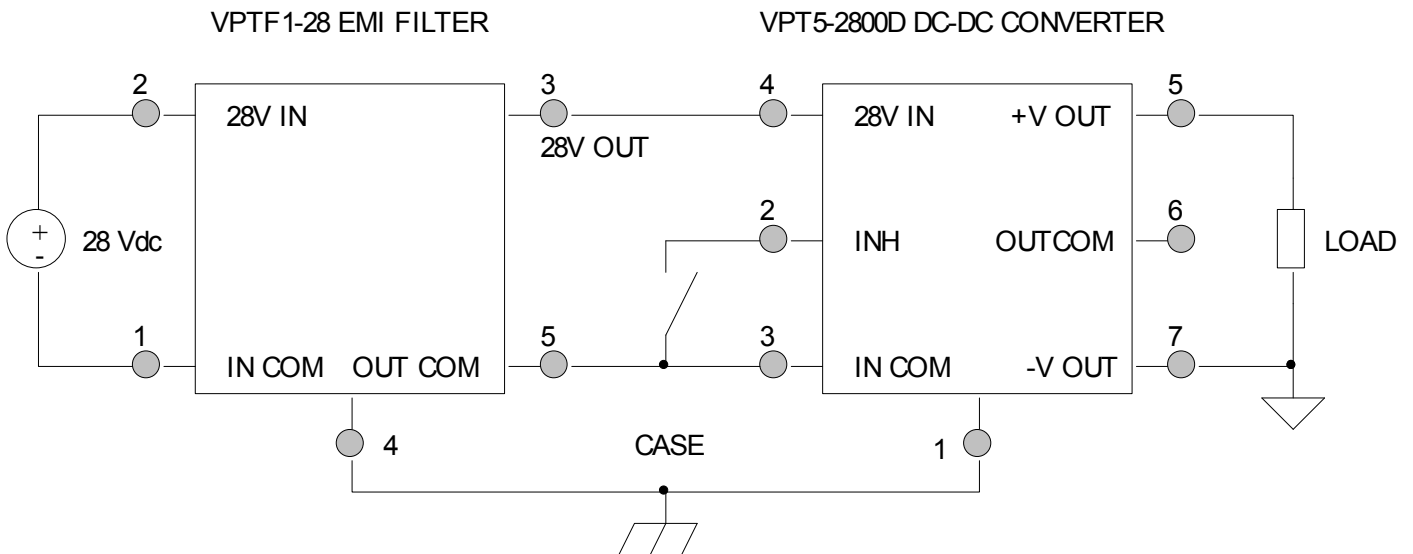

Figure 3  
(Shown with optional EMI filter)

## CONNECTION DIAGRAMS

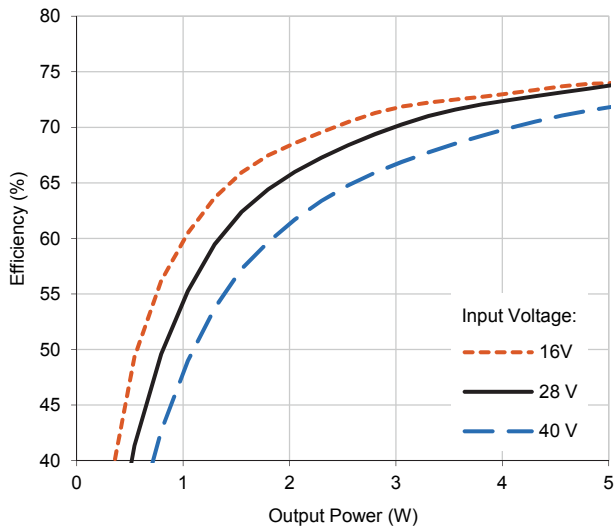

**Figure 4** –Inhibit Circuit  
(Shown with optional capacitor for turn-on delay)

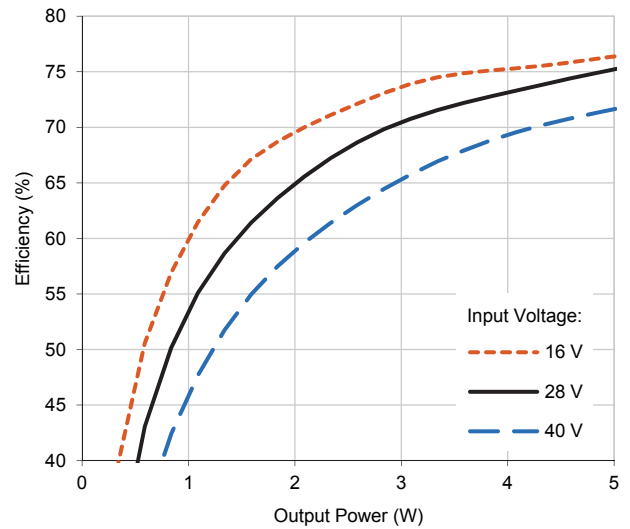

**Figure 5** – Stacked Output Connection  
(Shown with optional EMI filter)

## EFFICIENCY PERFORMANCE CURVES ( $T_{CASE} = 25^{\circ}C$ , Full Load, Unless Otherwise Specified)



**Figure 6 – VPT5-2805D**  
Efficiency (%) vs. Output Power (W)



**Figure 7 – VPT5-2812D**  
Efficiency (%) vs. Output Power (W)

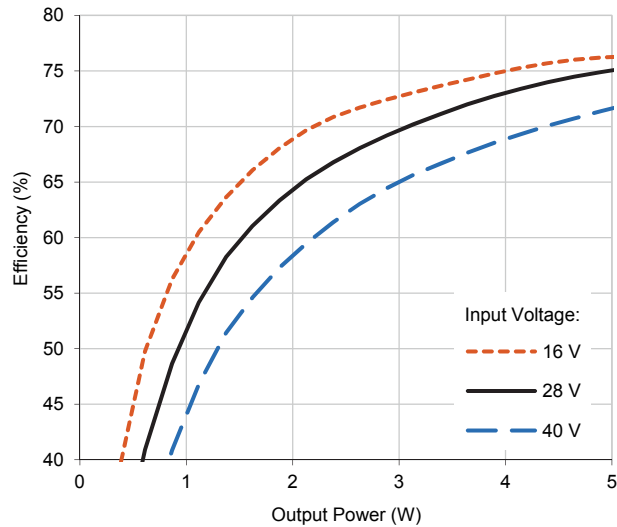

**Figure 8 – VPT5-2815D**  
Efficiency (%) vs. Output Power (W)



## CROSS REGULATION CURVES ( $T_{CASE} = 25^{\circ}C$ , Full Load, Unless Otherwise Specified)

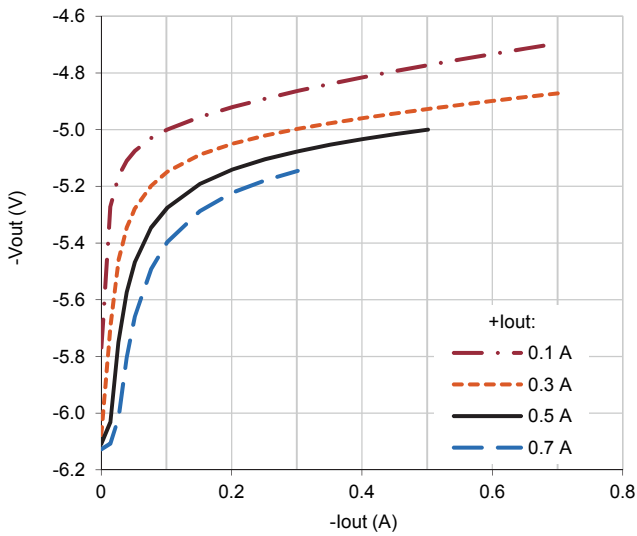

**Figure 9 – VPT5-2805D**  
-Vout (V) vs. -Iout (A)

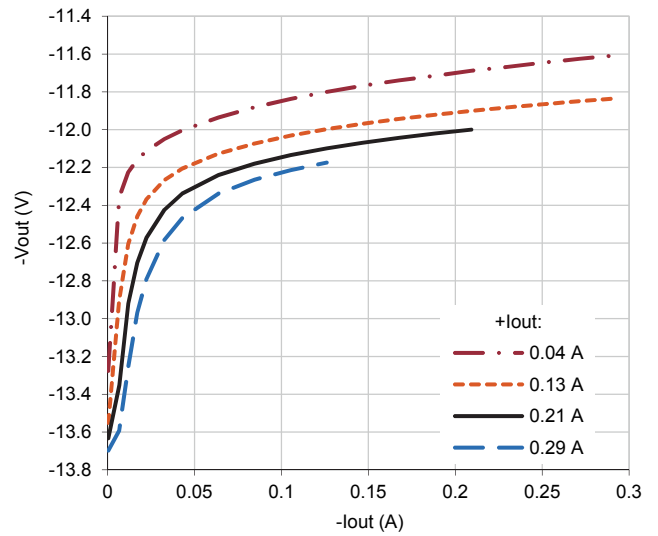

**Figure 10 – VPT5-2812D**  
-Vout (V) vs. -Iout (A)

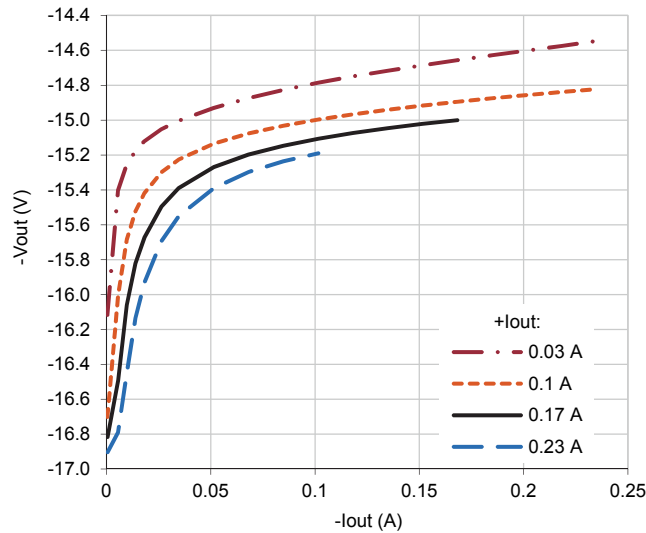

**Figure 11 – VPT5-2815D**  
-Vout (V) vs. -Iout (A)

## EMI PERFORMANCE CURVES

( $T_{CASE} = 25^{\circ}C$ ,  $V_{IN} = +28V \pm 5\%$ , Full Load, Unless Otherwise Specified)

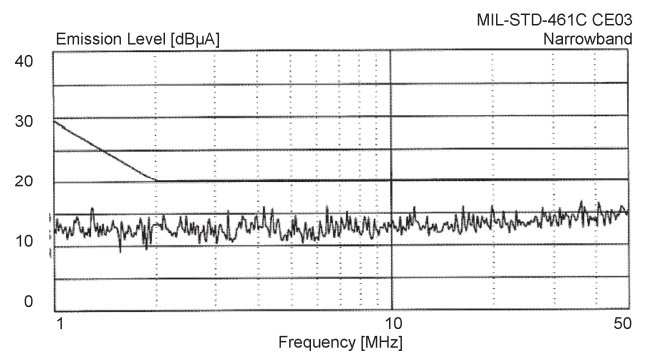
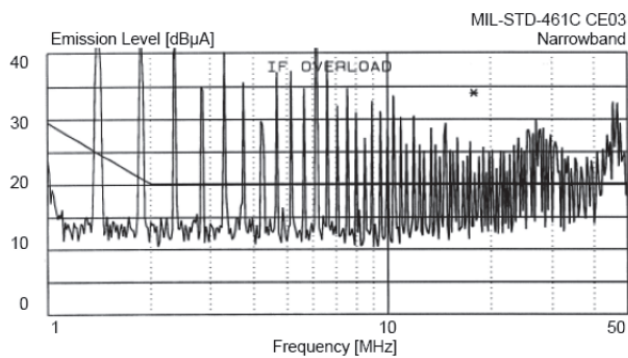
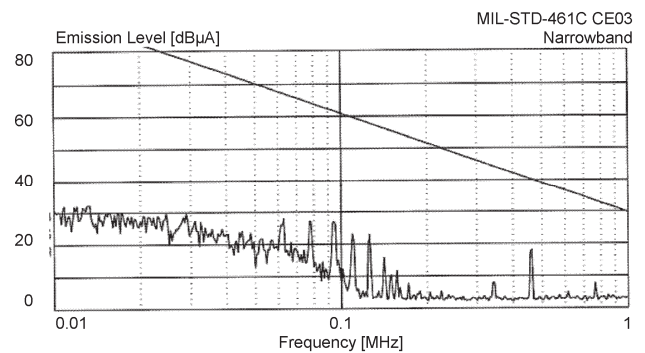
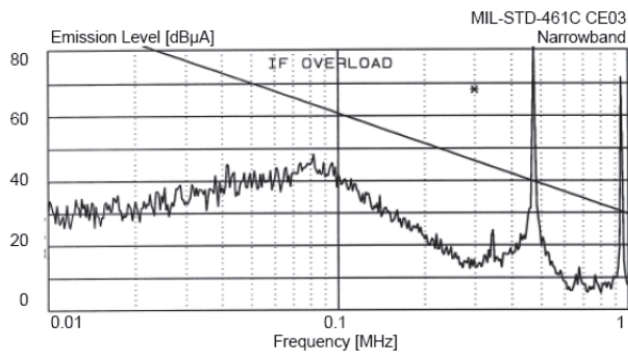

**Figure 12** – VPT5-2800D without EMI Filter

**Figure 13** – VPT5-2800D with VPTF Series EMI Filter

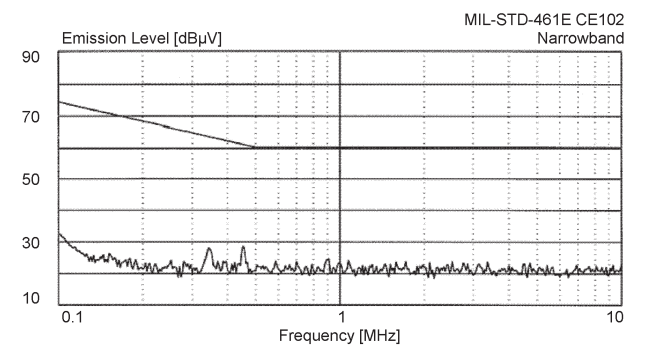
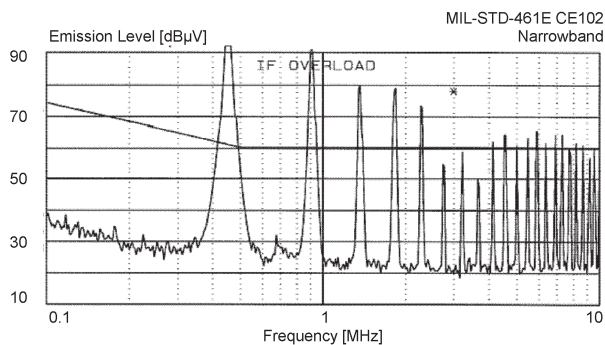
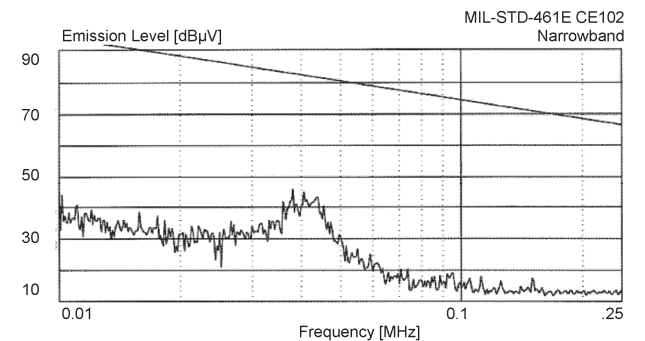
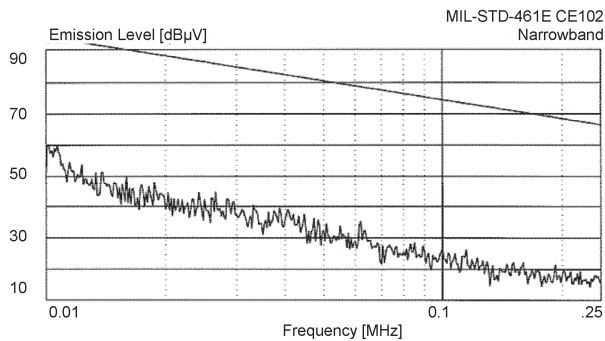

**Figure 14** – VPT5-2800D without VPTF Series EMI Filter

**Figure 15** – VPT5-2800D with VPTF Series EMI Filter

## STANDARD METAL PACKAGE

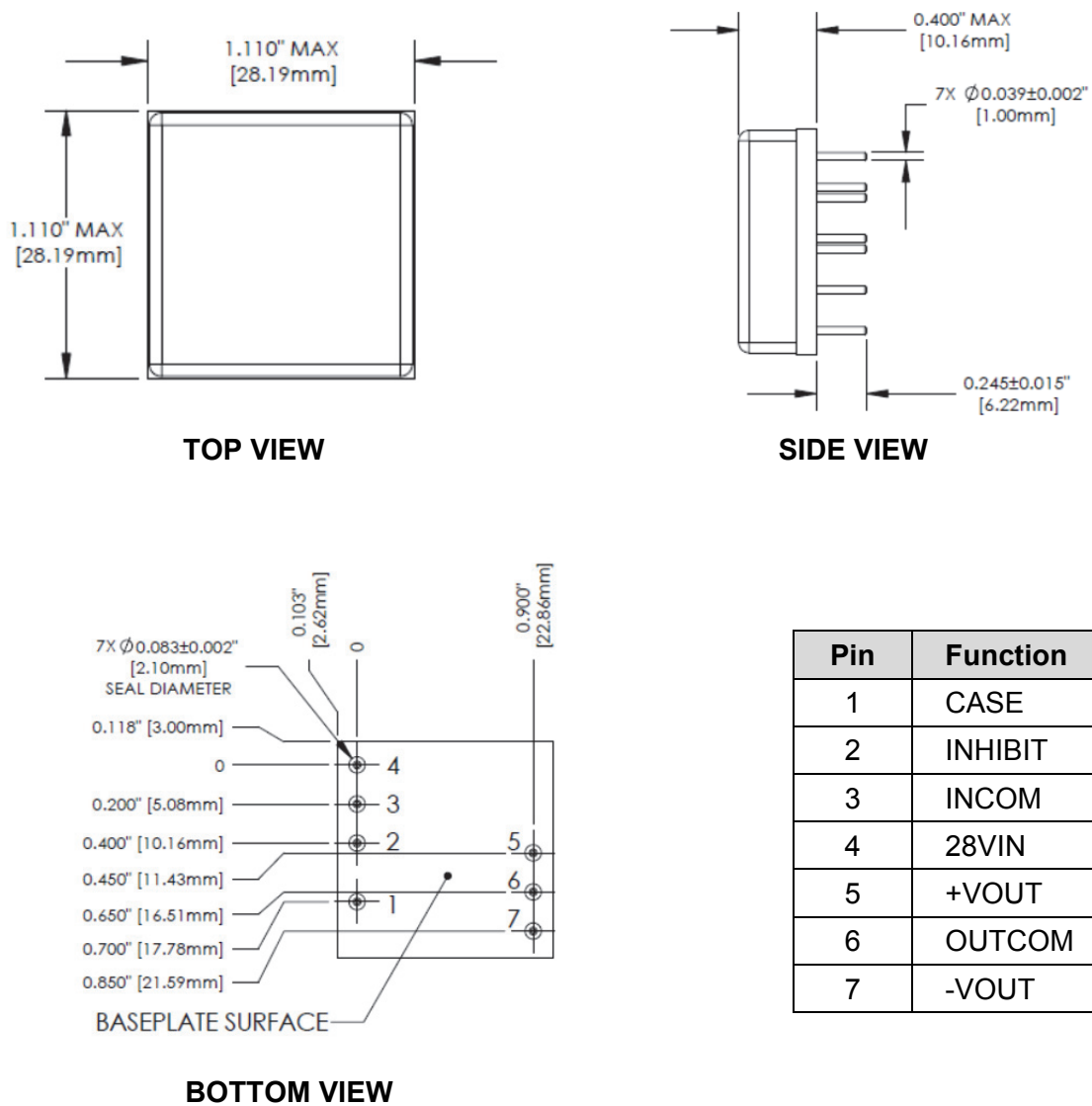

**Figure 16 – Package and Pinout**  
(Dimensional Limits are  $\pm 0.005$ " Unless Otherwise Stated)

### Package Notes

1. Case temperature is measured on the center of the baseplate surface.
2. Materials: Baseplate – aluminum, conductive conversion coating.  
Cover – nickel plated.  
Pins - copper, gold over nickel plating.
3. This Package is not hermetic. VPT offers a wide range of hermetic products. Please contact VPT for details if hermetic products are required.
4. For applications requiring exposure to liquid cleaning, please contact VPT.

**PACKAGE PIN DESCRIPTION**

Pin	Function	Description
1	CASE	Case Connection.
2	INHIBIT	This is an open collector input. Logic Low = Disabled Output. Connect the inhibit pin to input common to disable the output. Unconnected, open collector or open drain = Enabled Output.
3	INCOM	Input Return Connection.
4	28VIN	Positive Input Voltage Connection.
5	+VOUT	Positive Output Voltage Connection.
6	OUTCOM	Output Return Connection.
7	-VOUT	Negative Output Voltage Connection.

**100% ENVIRONMENTAL SCREENING**

Screening	Condition
Internal Visual	IPC-A-610, Class 3
Stabilization Bake	MIL-STD-883, Method 1008, Condition B, 125°C, 24 hours
Temperature Cycling	MIL-STD-883, Method 1010, Condition B, -55°C to +125°C, 10 Cycles
Burn-In	96 hours at +100°C
Final Electrical	100% at 25°C
External Visual	Internal Procedure

## ORDERING INFORMATION

VPT5-	28	05	D
1	2	3	4

(1) Product Series	(2) Nominal Input Voltage		(3) Output Voltage		(4) Number of Outputs	
VPT5-	28	28 Volts	05 12 15	±5 Volts ±12 Volts ±15 Volts	D	Dual

## CONTACT INFORMATION

To request a quotation or place orders please contact your sales representative or the VPT Inc. Sales Department at:

**Phone:** (425) 353-3010  
**Fax:** (425) 353-4030  
**E-mail:** [vptsales@vptpower.com](mailto:vptsales@vptpower.com)

All information contained in this datasheet is believed to be accurate, however, no responsibility is assumed for possible errors or omissions. The products or specifications contained herein are subject to change without notice. VPT, its logo and tagline are registered trademarks in the U.S. Patent and Trademark Office.